

The Series 450 Programmable Integral Temperature Transmitter is ideal for monitoring temperature in highly moist or corrosive environments and in small areas such as pipes and tanks. The unit consists of a 4-wire Pt100 RTD sensor, built-in (4 to 20) mA transmitter, and process connection. The integral design eliminates all external screw connections simplifying the electrical installation process and solving the problems caused by moisture, loose connections, and corrosion. A "quick disconnect" M12 plug adapter connects the transmitter to a PC for ease of calibration, re-programming, and wiring accuracy.

SERIES 450 PROGRAMMABLE INTEGRAL TEMPERATURE TRANSMITTER

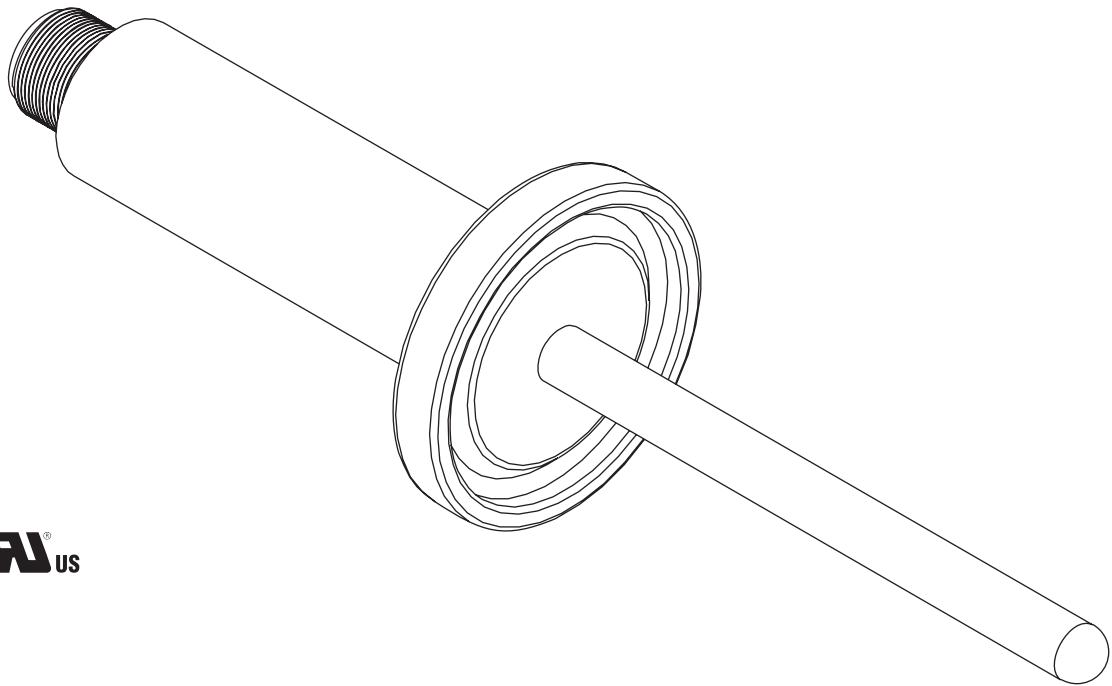

Application Areas

- PC programmable temperature transmitter for converting Pt100 input signal into a scaleable (4 to 20) mA analog output signal
- Platinum Resistance Thermometer (RTD)
- Ideal for use in applications where sanitary wash-down procedures are required
- Compact design is well suited for use in small areas such as tanks and pipes
- Used for measuring temperatures from (-51 to 160) °C [-60 to 320] °F

Features and Benefits

- PC programmable transmitter with (4 to 20) mA output
- Reliable measurements despite fluctuations in ambient temperature
- Available in threaded and Clean-In-Place connections
- RFI/EMI Protected, CE marked
- cULus UL Recognized Component

MINIATURE CIP RTD ASSEMBLY

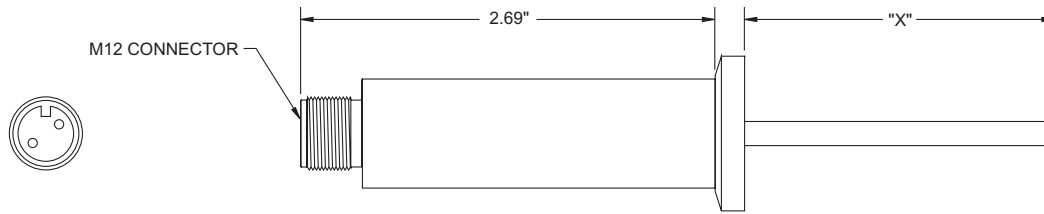

See Food & Dairy Section For Ordering Information



CIP RTD ASSEMBLY

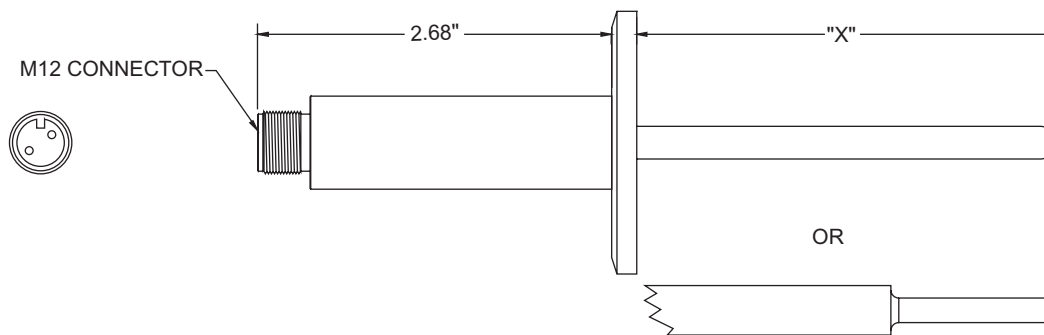

See Food & Dairy Section For Ordering Information



RTD ASSEMBLY WITH NO PROCESS FITTING

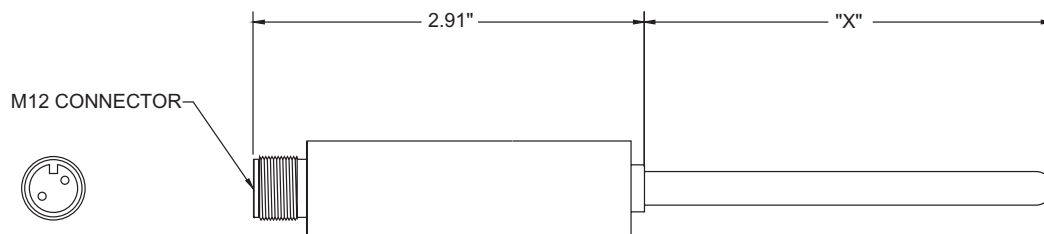

See RTD Section For Ordering Information

RTD ASSEMBLY WITH THREADED CONNECTION

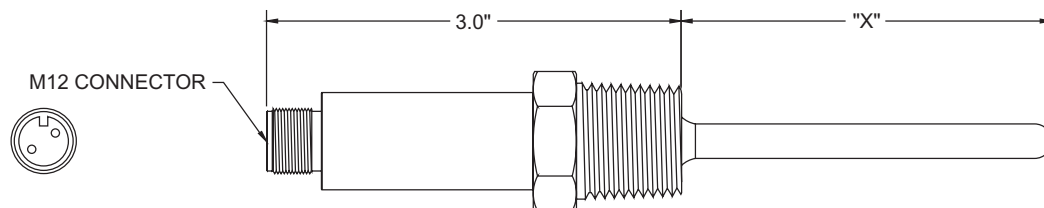

See RTD Section For Ordering Information

Resistance Thermometer Input (RTD)

TYPE	MEASUREMENT RANGE	MINIMUM RANGE
Pt100 ($\alpha = 0.00385$)	(-51 to 160) °C [-60 to 320] °F	10 °C [18 °F]
Connection Type	4 wire connection (standard)	
Sensor current	≤ 0.6 mA	

Output (Analog)

Output signal	(4 to 20) mA or (20 to 4) mA
Transmission as	Temperature linear
Maximum load	$(V_{\text{power supply}} - 10 \text{ V}) / 0.023 \text{ A}$ (current output)
Induced current required	≤ 3.5 mA
Current limit	≤ 23 mA
Switch on delay	2 s
Electronic response time	1 s

Failure Mode

Undershooting measurement range	Decreases to 3.8 mA
Exceeding measurement range	Increases to 20.5 mA
Sensor breakage/short circuit	≤ 3.6 mA or ≥ 21.0 mA

Accuracy

Electronics measurement error	0.1 °C or 0.08% ^[1]
Reference conditions	Calibration temperature (23 ± 5) °C [73 ± 9] °F
Sensor measurement error	Class A ± (0.15 + 0.002 t) °C Class B ± (0.30 + 0.005 t) °C Band 1 ± (0.26 + 0.0042 t) °C Band 3 ± (0.08 + 0.0017 t) °C Band 5 ± (0.03 + 0.0017 t) °C t = value of temperature without regard to sign, °C
Influence of power supply	± 0.01%/V deviation from 24 V ^[2]
Load influence	± 0.02%/100 Ω ^[2]
Temperature drift	$T_d = \pm (15 \text{ ppm/}^\circ\text{C} \times (\text{full scale value} + 200) + 50 \text{ ppm/}^\circ\text{C of set measuring range}) \times \Delta\vartheta$ $\Delta\vartheta$ = deviation of ambient temperature from the reference operation condition
Electronics long term stability	≤ 0.1 °C/year ^[3] or ≤ 0.05%/year ^{[1][3]}

[1] % is related to the adjusted measurement range (the value to be applied is the greater)

[2] All data is related to a measurement and value of 20 mA

[3] Under reference conditions

Electrical Connection

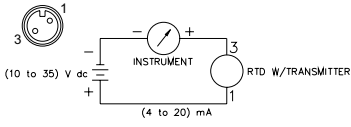
<p>Electrical connection</p>	 <p>Electrical connection of the compact thermometer (view from above) - M12 plug, 4-pin Pin 1: Power supply (10 to 35) V dc; Current output (4 to 20) mA Pin 2: PC configuration cable connection Pin 3: Power supply 0 V dc; current output (4 to 20) mA Pin 4: PC configuration cable connection</p>
<p>Power supply</p>	<p>$U_b = (10 \text{ to } 35) \text{ V dc}$, polarity protected</p>
<p>Allowable ripple</p>	<p>$U_{ss} \leq 3\text{V}$ at $U_b \geq 13\text{V}$, $f_{\text{max}} = 1 \text{ kHz}$</p>



Environmental Conditions

<p>Ambient Temperature</p>	<p>(-40 to 85) °C [-40 to 185] °F</p>
<p>Storage Temperature</p>	<p>(-40 to 100) °C [-40 to 212] °F</p>
<p>Climatic Class</p>	<p>EN 60 654-1, class C</p>
<p>Condensation</p>	<p>Permitted</p>
<p>Ingress protection</p>	<p>IP 67</p>
<p>Shock resistance</p>	<p>4g / (2 to 150) Hz as per IEC 60 068-2-6</p>
<p>EMC immunity</p>	<p>Interference immunity and interference emission as per EN 61 326-1 (IEC 1326)</p>

Process

<p>Process temperature limit</p>	<table border="0"> <tr> <td>MAXIMUM AMBIENT</td> <td>MAXIMUM PROCESS</td> </tr> <tr> <td>to 25 °C [77 °F]</td> <td>160 °C [320 °F]</td> </tr> <tr> <td>to 40 °C [104 °F]</td> <td>135 °C [275 °F]</td> </tr> <tr> <td>to 60 °C [140 °F]</td> <td>120 °C [248 °F]</td> </tr> <tr> <td>to 85 °C [185 °F]</td> <td>100 °C [212 °F]</td> </tr> </table>	MAXIMUM AMBIENT	MAXIMUM PROCESS	to 25 °C [77 °F]	160 °C [320 °F]	to 40 °C [104 °F]	135 °C [275 °F]	to 60 °C [140 °F]	120 °C [248 °F]	to 85 °C [185 °F]	100 °C [212 °F]
MAXIMUM AMBIENT	MAXIMUM PROCESS										
to 25 °C [77 °F]	160 °C [320 °F]										
to 40 °C [104 °F]	135 °C [275 °F]										
to 60 °C [140 °F]	120 °C [248 °F]										
to 85 °C [185 °F]	100 °C [212 °F]										

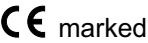
Approvals

  	<p>Unit complies with the legal requirements set forth by the EU regulations.</p> <p>UL Recognized Component</p> <p>3A Sanitary Council Standard 74- (CIP sensors only)</p>
--	---